

```

def p_dispatcher(self, e):
    status = return_status.HANDLED
    [region.post_fifo(e) for region in self.p_regions]
    [region.complete_circuit() for region in self.p_regions]
    return status
  
```

region has a reference(s) to other regions and a reference to its outer xml chart

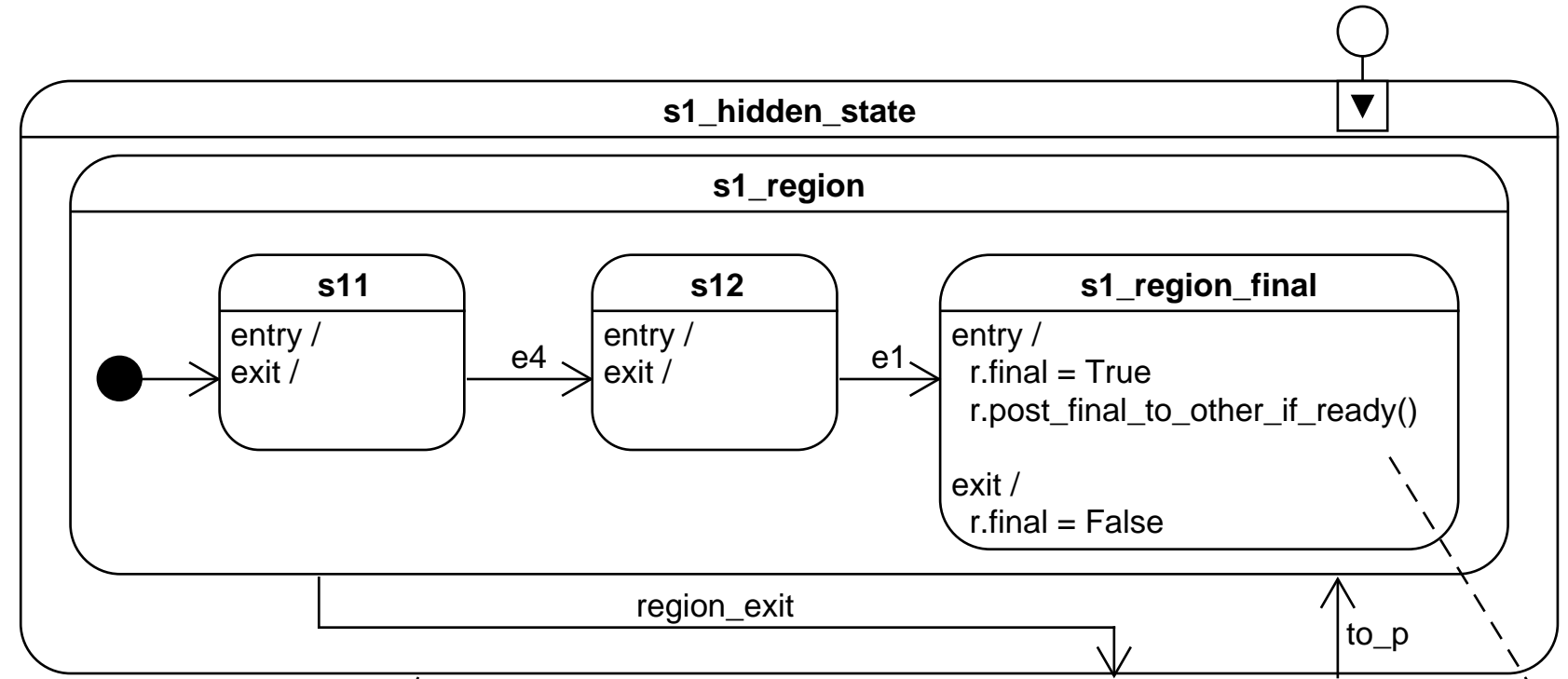
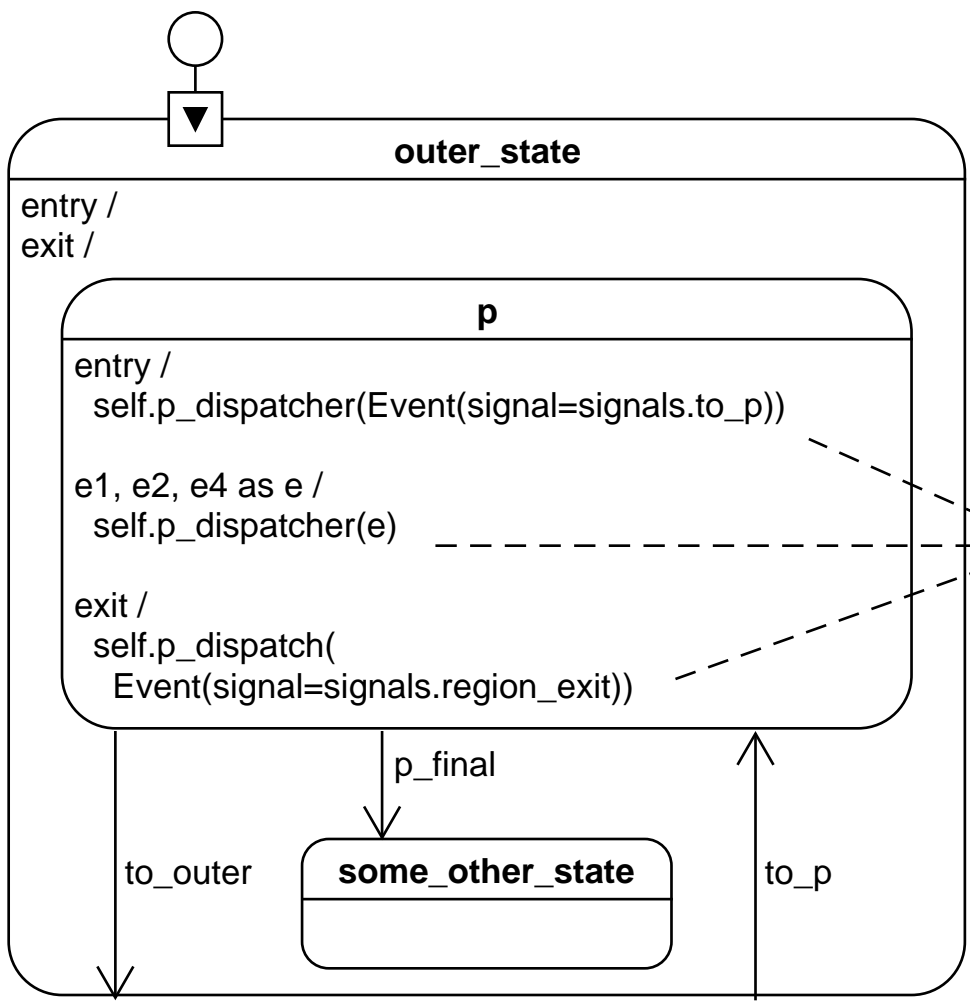

«pattern» Orthogonal Components

«pattern» Reminder

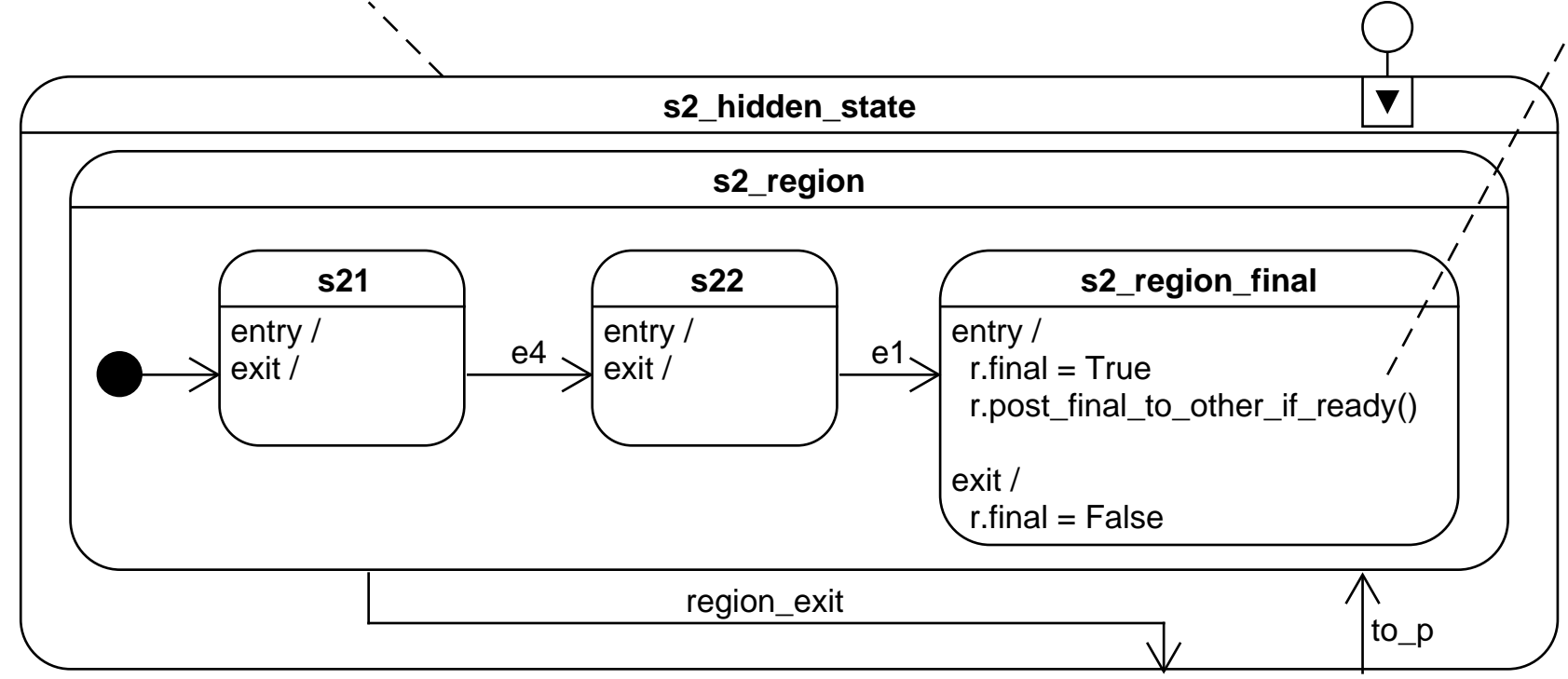

```

def post_p_final_to_outer_if_ready(self):
    ready = False if self.regions is None and len(self.regions) < 1 else True
    for region in self.regions:
        ready &= True if region.final else False
    if ready:
        self.outer.post_fifo(self.final_event)
  
```