

ao.start_at(c2)

Startcharts are initialized to have their initial state outside of your HSM before you call their start_at method

So, this start_at call will cause a run the entry conditions of c and c2 and then the init condition of c2

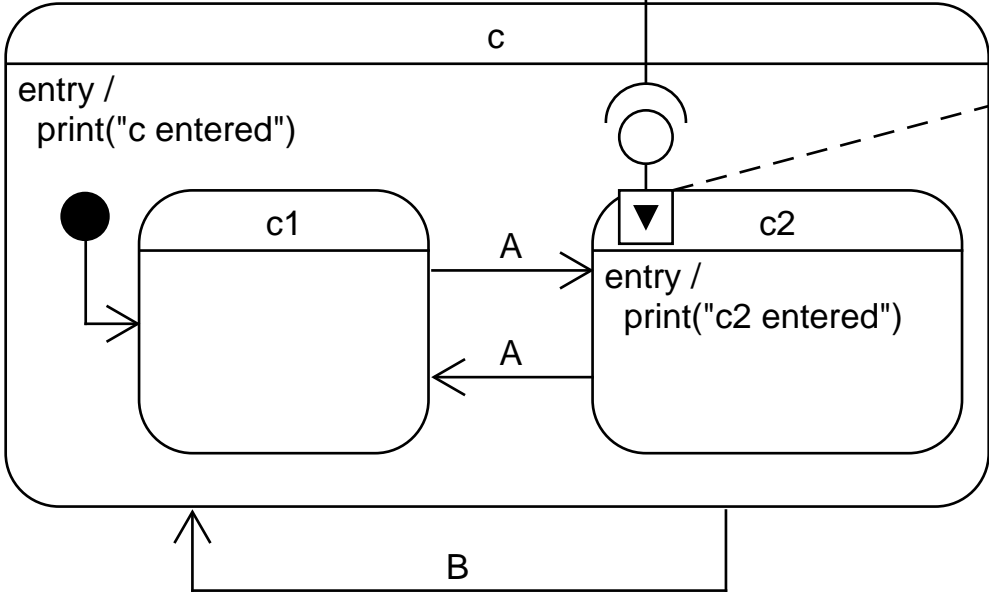

Using an attachment point like this is NOT UML compliant, but it shows where you want to start your statechart when you turn it on