

Object is fed which classes to construct:
I don't know how to draw this with UML

```
automata = TwoDCellularAutomata(
    generations=200,
    machine_cls=Rule30,
    wall_cls=WallLeftWhiteRightWhite,
    cells_per_generation=50)
```

"Make a 2d automata using the Rule30 machine, force the left and right walls white. Make the graphing paper 50 squares wide and run the automata for 200 lines."

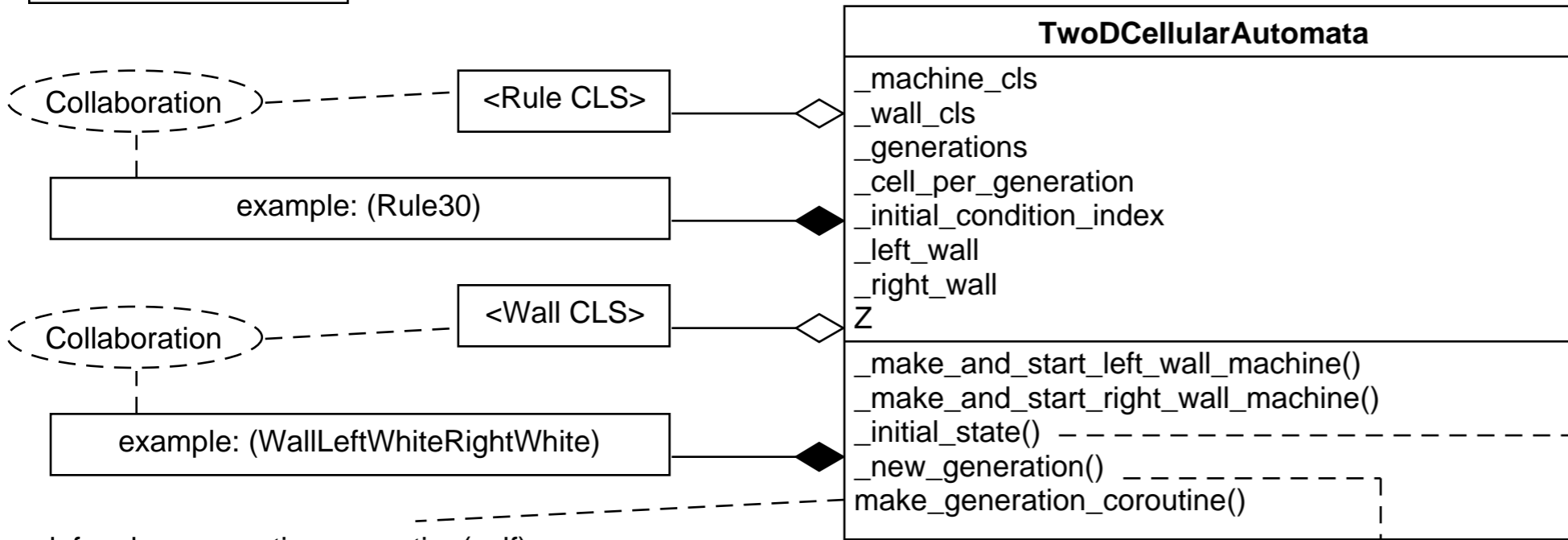

```
def make_generation_coroutine(self):
    self.initial_state()
    yield self.Z
    while True:
        self.next_generation()
        yield self.Z
```

make_generation_coroutine is used by our Canvas object to make the coroutine that will update Z's color map

Create the next line's color map

and the next, and the next ...

Create the first line's color map

